

# INSTALLATION INSTRUCTIONS FOR INSTALLING A 110 AND 120 MILLIMETER CIGARETTE CONVERSION KIT IN A NATIONAL VENDORS®, CROWN LINE®, CABARET 36 ELECTRIC CIGARETTE MERCHANDISER

These instructions cover the procedure for installing a 110 and 120 millimeter Cigarette Conversion Kit in a Crown Line, Cabaret 36 Electric Cigarette Merchandiser.

Read these instructions carefully and thoroughly before installing the Kit. Retain these instructions for part number and installation information.

Kit, Part Number 236-6237, contains the following parts:

Part Number	Description	Quantity
236-7121	Center Magazine Assembly	1
213-4020	Spring	12
236-7114	120 mm Ejector Tilt Bracket	1
9900-033	No.8 External Tooth Lockwasher	2
404-1106	No.8-18 x 3/4 RHS S/T Screw	2
*236-7107	Lower Pack Spacer	4
236-7045	Pack Spacer Information Label	1
9900-046	No.8-32 x 1/4 RHS S/T Screw	6
9900-063	No.8-32 x 3/8 RHS S/T Screw	3
236-6236	Installation Instructions	1
	* * *	

\*Used only for narrow 120 mm cigarette packs. See Loading Instructions for 120 mm cigarette packs.

**Special Tools Required**  
No.28 and No.39 Drill Bit  
Drill

### NOTE

*The replacement Center Magazine Assembly, included in the Kit, is capable of vending Regulars, King-size, 100, 110, and 120 mm cigarettes, however, the Front and Rear Magazines can vend only Regulars, King-size, and 100 mm cigarettes.*

## TO INSTALL THE KIT

### A. PARTS REMOVAL

1. Unlock and open the Cabinet Door. See Figure 1.
2. Depress the red Latch Lever and swing out the Front and Center Magazines. See Figure 1.
3. Unload columns 1, 6, and 12 of the Front Magazine and all the columns of the Center Magazine.

4. Remove the Screw attaching the Wire Clamp from the end of the Center Magazine. Retain the Screw. See Figure 2.
5. Disconnect the Switch Connector from the Vend Flap Switch. See Figure 2.

### WARNING

1. Be sure the Front and Center Magazines are swung out of the Cabinet before removing the Center Magazines to avoid possible damage to the Merchandiser.
2. The Center Magazine is a heavy unit. Two people will be required to remove the Center Magazine from the Merchandiser.

6. Remove six Screws attaching the Center Magazine to the Front Magazine and remove the Center Magazine from the Merchandiser. See Figure 3.

### NOTE

*Step A7 refers to the 12 Ejector Assemblies on the Carriage Assembly.*

7. Remove the Spring extending from the Solenoid Link to the Ejector Link on each Ejector Assembly on the Carriage Assembly. See Figure 4.

### B. INSTALLATION OF THE KIT

1. Replace the Springs removed in Step A7 with the twelve Springs, Part Number 213-4020, included in the Kit, by attaching one end of the Spring to the top of the Solenoid Link and the other end to the Ejector Link on each Ejector Assembly. See Figure 4.

### WARNING

**The replacement Center Magazine Assembly is a heavy unit. Two people will be required to install it in the Merchandiser.**

2. Install the replacement Center Magazine Assembly, Part Number 236-7121, included in the Kit, in the Merchandiser by attaching the Center Magazine to the Front Magazine with six No.8-32 x 1/4 Round Head Self Tapping Screws, Part Number 9900-046, included in the Kit. See Figure 3.
3. Connect the Vend Flap Switch Connector to the Vend Flap Switch on the Center Magazine Assembly. See Figure 2.

Printed in U.S.A.

LGE

Copyright © 1975 by National Vendors

A Division of UMC Industries, Inc.

236-6236  
Rev. A

R | L

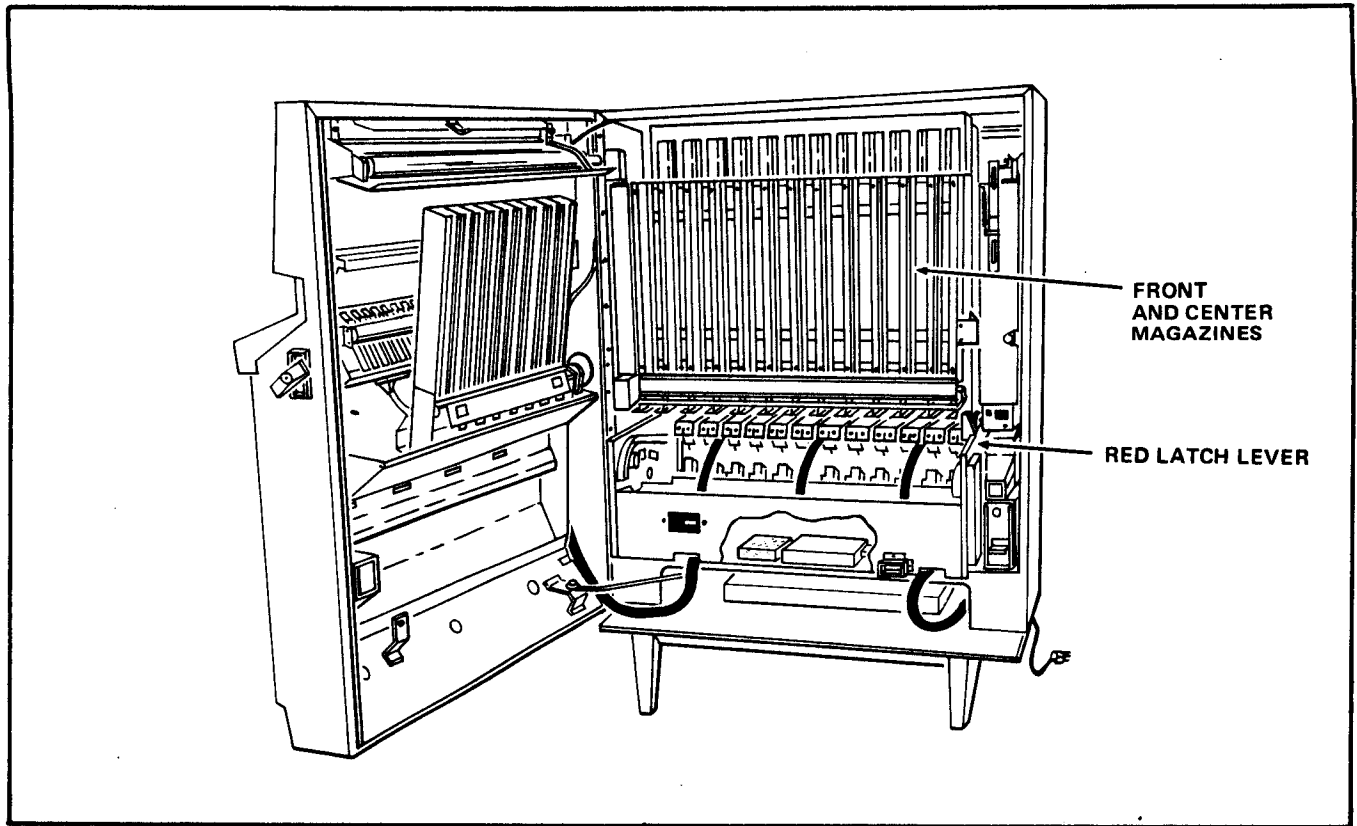

FIGURE 1

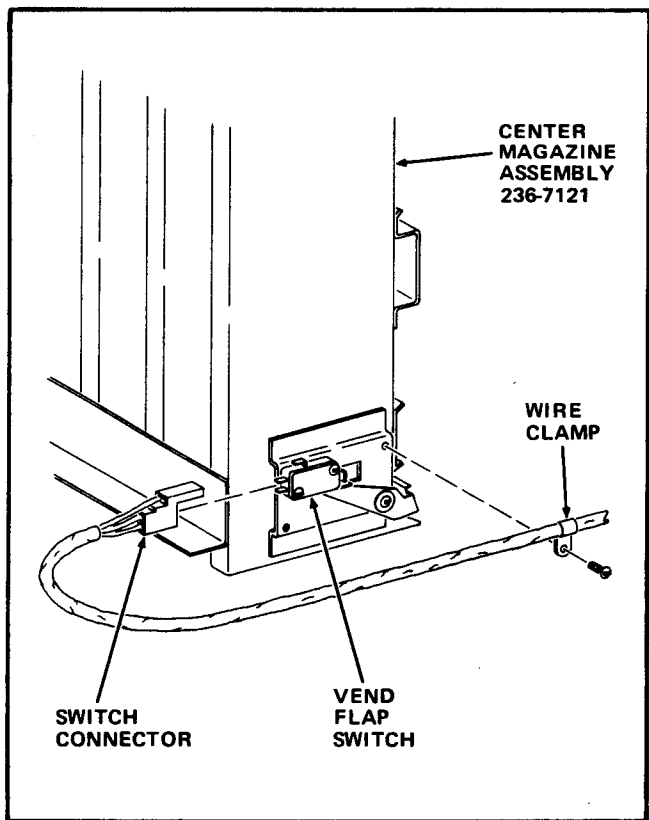

FIGURE 2

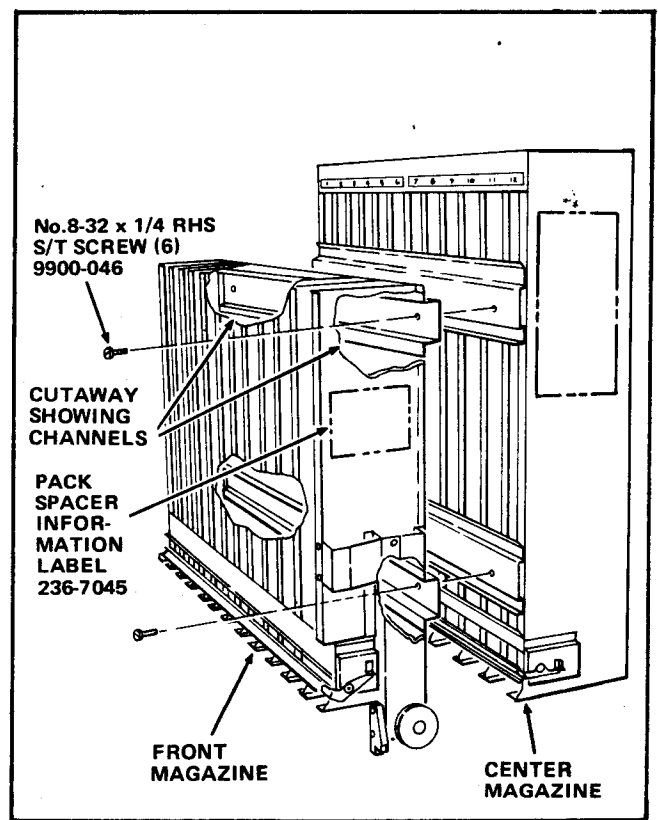

FIGURE 3

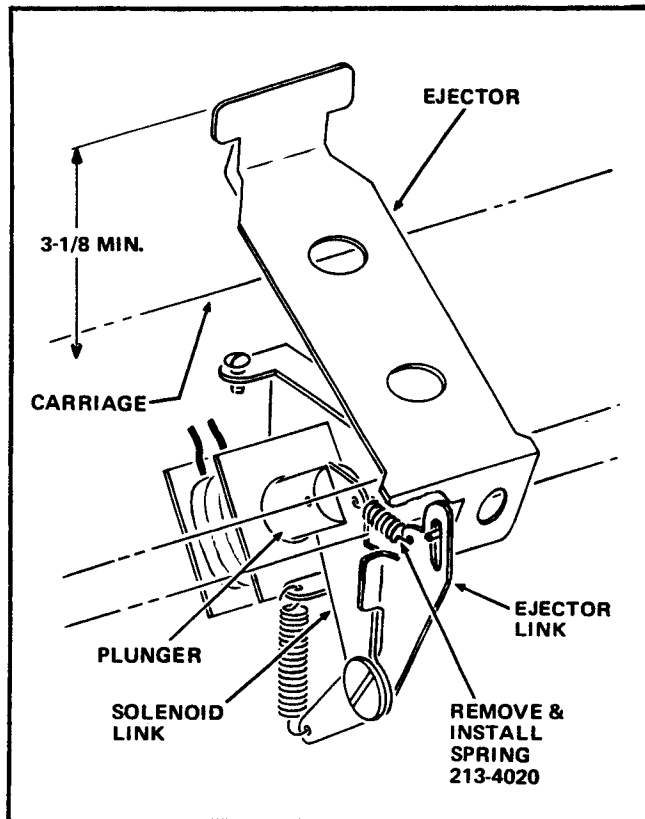

FIGURE 4

4. Attach the Wire Clamp on the Vend Flap Switch Harness to the end of the Center Magazine with the Screw removed in Step A-4. See Figure 2.
5. Place the 120 mm Ejector Tilt Bracket, Part Number 236-7114, included in the Kit, on top of the Front Spacer Sidewall Pan of the Mechanism Assembly, so both material edges are flush and make sure the extensions of the 120 mm Ejector Tilt Bracket are in front of the Left and Right Guide Rails. Mark through the holes in the 120 mm Ejector Tilt Bracket and onto the Front Spacer Sidewall Pan and onto the Left and Right Guide Rails to locate holes for drilling. See Figure 5 and Figure 5 View A.
6. Using a No.28 Drill Bit, drill three .140 diameter holes through the Front Spacer Sidewall Pan at the three points marked in Step B5. See Figure 5.
7. Using a No.30 Drill Bit, drill a .128 diameter hole in the Left and Right Guide Rail through the points marked in Step B5. See Figure 5.
8. Attach the 120 mm Ejector Tilt Bracket to the Front Spacer Sidewall Pan with three No.8-32 x 3/8 Round Head Self Tapping Screws, Part Number 9900-063, included in the Kit. See Figure 5.

9. Attach the ends of the 120 mm Ejector Tilt Bracket to the Left and Right Guide Rails using two No.8 External Tooth Lockwashers, Part Number 9900-033, and two No.8-18 x 3/4 Round Head Self Tapping Screws, Part Number 404-1106, both included in the Kit. See Figure 5.

10. Push the front of the Ejector to lock the plastic Switch Mount Latch in the Switch Actuator; then move the Ejector Carriage Assembly forward by pushing on the Interlock Switch until the Ejectors contact the 120 mm Ejector Tilt Bracket. Adjust the Screws attaching the 120 mm Ejector Tilt Bracket until the Ejectors at their highest point are approximately 1/8" below the Front Magazine. See Figure 5 View A.

11. Remove the Pack Spacer Information Label from the end of the Front Magazine.

12. Peel the backing off the Pack Spacer Information Label, Part Number 236-7045, included in the Kit, and attach it to the end of the Front Magazine. See Figure 3.

13. Close the Front and Center Magazine Assembly.

14. Close and lock the Cabinet Door.

#### C. LOADING INSTRUCTIONS FOR THE REPLACEMENT CENTER MAGAZINE ASSEMBLY

The Center Magazine may be loaded with:

- (1) Regular-size packs, or
- (2) King-size packs or king-size box packs, or
- (3) 100 mm-size packs, 100 mm-size box packs, or 100 mm-size thin packs.
- (4) 110 mm-size packs or 110 mm-size box packs.
- (5) 120 mm-size packs or 120 mm-size box packs.

#### NOTE

*The replacement Center Magazine Assembly contains 2 Narrow Pack Spacers, 9 Medium Pack Spacers, and 1 Wide Pack Spacer installed in the columns. The Pack Spacers are completely interchangeable. See Figure 6 to determine the correct Pack Spacer for each type of cigarette pack.*

1. To Load the Center Magazine with Regular-Size Packs:
  - a. Unlock and open the Cabinet Door.
  - b. Depress the red Magazine Latch and swing the Front and Center Magazine Assembly open.

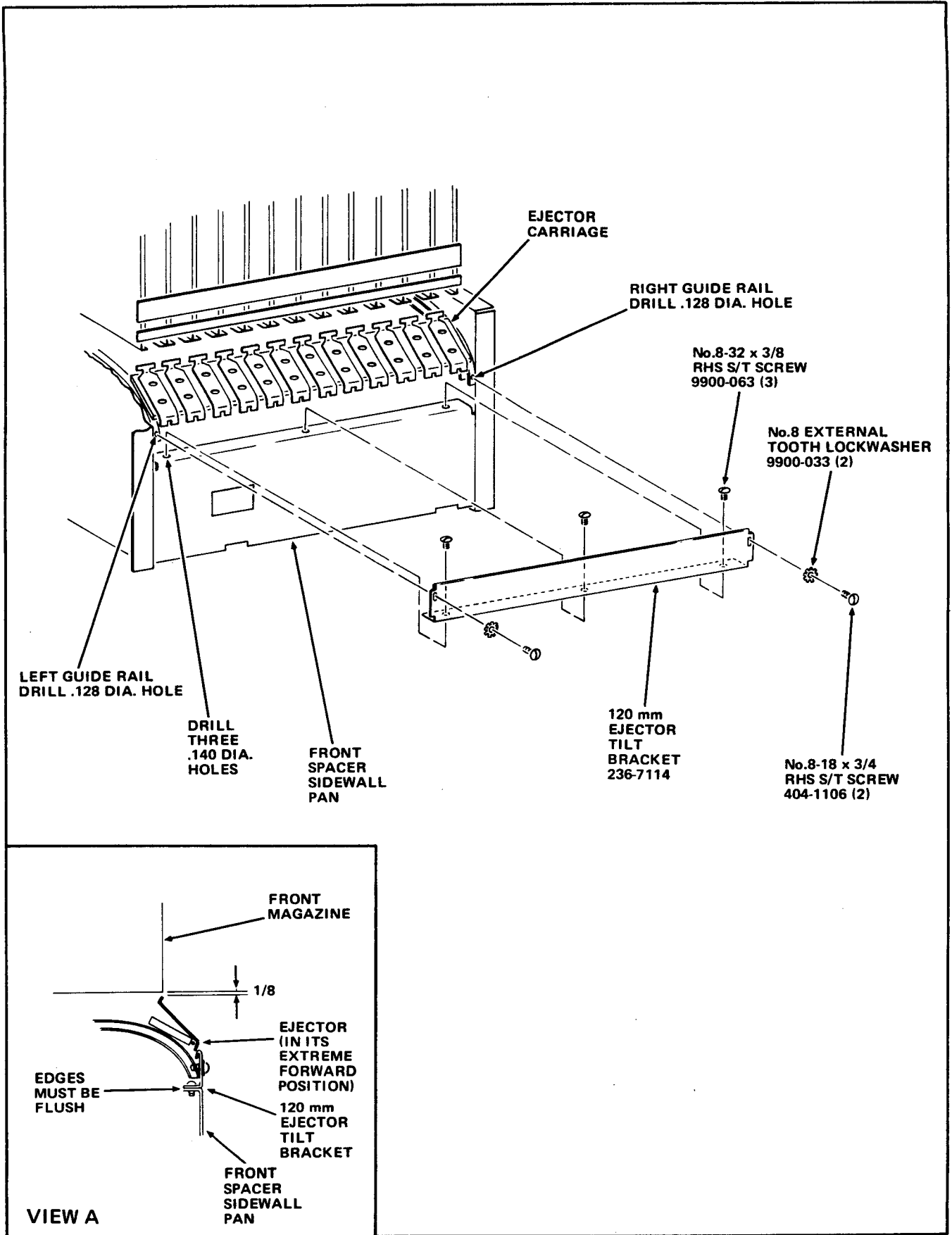

**FIGURE 5**

- c. Remove any incorrect Pack Spacer from the Column by lifting out the Pack Spacer.
  - d. Install the Wide Pack Spacer, Part Number 236-7109, in the Column with the Tabs to the Front of the Merchandiser. Slide the Pack Spacer down, so both Tabs engage both Slots in the Column. See Figure 7.
  - e. Load the Column with a maximum of 30 regular-size packs. Place the packs in the Center Magazine Column with the Tax Stamp facing toward the front of the Merchandiser. Observe the Tax Stamp through the front inspection window, when Door is closed.
  - f. Close the Front and Center Magazine Assembly.
  - g. Close and lock the Cabinet Door.
2. To Load the Center Magazine with King-Size Packs or King-Size Box Packs:
- a. Unlock and open the Cabinet Door.
  - b. Depress the red Magazine Latch and swing the Front and Center Magazine Assembly open.

**HOW TO SELECT  
THE CORRECT PACK SPACER FOR THE CENTER MAGAZINE**

CIGARETTE TO BE VENDED	PACK SPACER REQUIRED			
	WIDE	MEDIUM	NARROW	NONE
REGULAR-SIZE PACKS	x	-	-	-
KING-SIZE PACKS OR KING-SIZE BOX PACKS	-	x	-	-
100 mm-SIZE PACKS OR 100 mm-SIZE BOX PACKS OR 100 mm-SIZE THIN PACKS	-	-	x	-
110 mm-SIZE 120 mm-SIZE PACKS OR BOX PACKS	-	-	-	x

FIGURE 6

- c. Remove any incorrect Pack Spacer from the Column by lifting out the Pack Spacer.
  - d. Install a Medium Pack Spacer, Part Number 236-7110, as described in Step C-1-d.
  - e. Load the Column with a maximum of 30 king-size packs, or 30 king-size packs. Place the packs, or boxes, in the Center Magazine Column with the Tax Stamp facing toward the front of the Merchandiser. Observe the Tax Stamp through the front inspection window, when the Door is closed.
  - f. Close the front and Center Magazine Assembly.
  - g. Close and lock the Cabinet Door.
3. To Load the Center Magazine with 100 mm-size Packs, 100 mm-size Box Packs or 100 mm-size Thin Packs:
- a. Unlock and open the Cabinet Door.
  - b. Depress the red Magazine Latch and swing the Front and Center Magazine Assembly open.
  - c. Remove any incorrect Pack Spacer from the Column by lifting out the Pack Spacer.

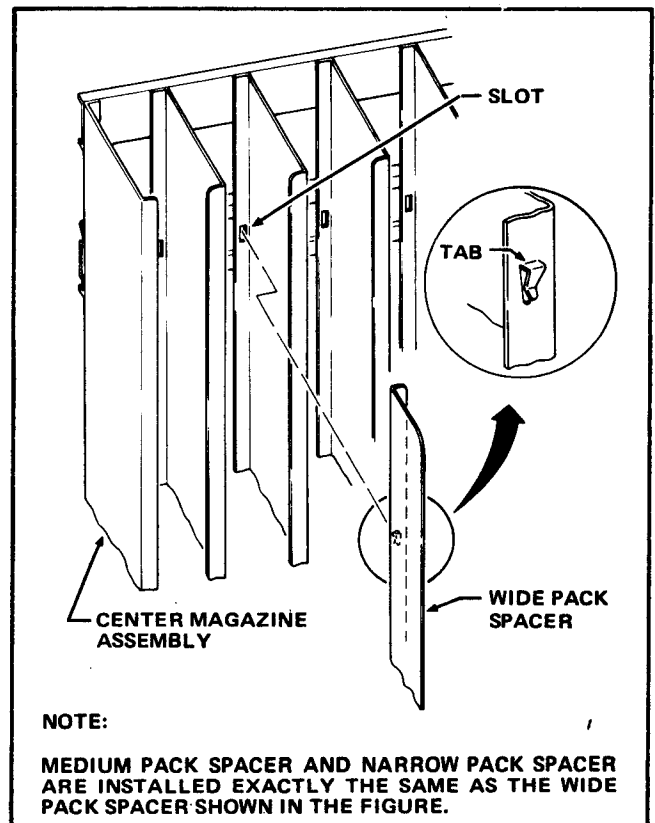
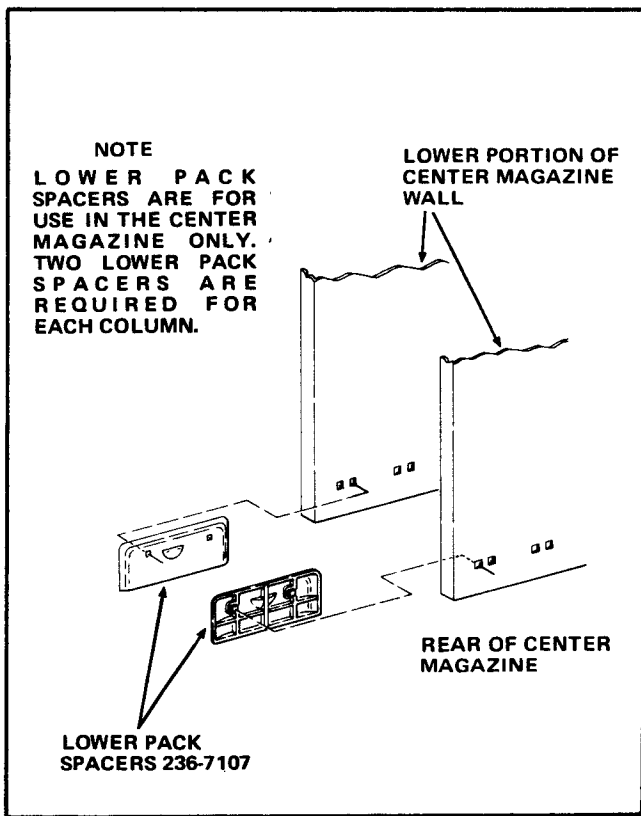

FIGURE 7

- d. Install a Narrow Pack Spacer, Part Number 236-7111, as described in Step C-1-d.
  - e. Load the Column with a maximum of thirty 100 mm-size packs, or thirty 100 mm-size box packs, or thirty 100 mm-size thin packs. Place the packs, or boxes, in the Center Magazine Column with the Tax Stamp facing toward the front of the Merchandiser. Observe the Tax Stamp through the front inspection window, when the Door is closed.
  - f. Close the Front and Center Magazine Assembly.
  - g. Close and lock the Cabinet Door.
4. To Load a Column of the Center Magazine with 110 mm-size Packs, 110 mm-size Box Packs, 120 mm size Packs or 120 mm-size Box Packs:
- a. Unlock and open the Cabinet Door.
  - b. Depress the red Magazine Latch and swing the Front and Center Magazine Assembly open.

**NOTE**

1. 120 mm Cigarette Packs vary in width. Each brand must be checked to determine if the use of Lower Pack Spacers, Part Number 236-7107, included in the Kit, are required.
2. Cigarette Packs 2 inches wide or less require the use of Lower Pack Spacers.
3. Two Lower Pack Spacers are required for each column.
  - c. Measure the width of the cigarette pack to determine if Lower Pack Spacers are required.
  - d. If Lower Pack Spacers are required, install two Lower Pack Spacers on the lower inside walls of the column that is to vend narrow packs by aligning the tabs on the back of the Lower Pack Spacers in the holes in the Magazine Walls and press downward locking into place See Figure 8.
- e. Load the Column with a maximum of thirty 110 mm-size packs, thirty 110 mm-size box packs, thirty 120 mm-size packs or thirty 120 mm-size box packs. Place the boxes in the column with the Tax Stamp facing toward the front of the Merchandiser. Observe the Tax Stamp through the front inspection window when the Door is closed.



**FIGURE 8**

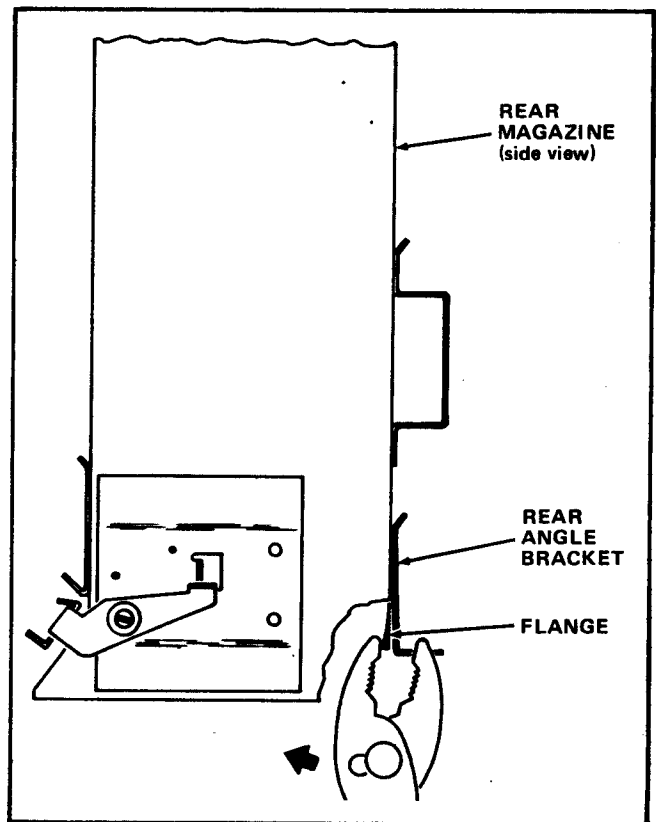

**FIGURE 9**

f. Close the Front and Center Magazine Assembly.

g. Close and lock the Cabinet Door.

#### D. TEST VENDING THE MERCHANDISER

With the Columns loaded, test vend each column in the Front, Center and Rear Magazines.

If a column fails to vend properly, the problem could be a faulty Solenoid and Bracket Assembly for that particular Column. Test the Solenoid and Bracket

Assembly by pushing in the plunger on the Solenoid Assembly. This will raise the Ejector. If the top edge of the Ejector will not raise more than 3 1/8 inches above the surface of the Carriage as shown in Figure 4, replace the Solenoid and Bracket Assembly, Part Number 236-6057.

If the Ejector should jam in Column 12 of the Rear Magazine while traveling to the rear to vend out of the Rear Magazine, the problem could be a gap between the flange on the Column and the Rear Angle Bracket. Use a pliers as shown in Figure 9, to bend the flange on the Column to close the gap.